

ОСНОВНЫЕ ВОЗМОЖНОСТИ ПРОДУКТОВ ЛИНЕЙКИ EFD

Gennady Dumnov

Январь
2011

Mentor
Graphics®

ОСНОВНОЙ МОДУЛЬ

*(функциональность для всех
продуктов – одинакова)*

FLOW SIMULATION (CFW) для SW

FloEFD (EFD.LAB) на базе SW
(поставляется совместно с SW OEM)

FloEFD.V5 (EFD.V5) для CATIA

FloEFD.Pro (EFD.Pro) для Pro/E

ДОПОЛНИТЕЛЬНЫЕ МОДУЛИ

*(поставляются только для
EFD продуктов)*

**Модуль –
«Электроника»**

Модуль – «Гиперзвук»

Модуль – «Горение»

Модуль – «Вентиляция»

ОСНОВНЫЕ ВОЗМОЖНОСТИ FLOEFD ПО МОДЕЛИРОВАНИЮ ФИЗИЧЕСКИХ ПРОЦЕССОВ (ВЕРСИЯ 10)

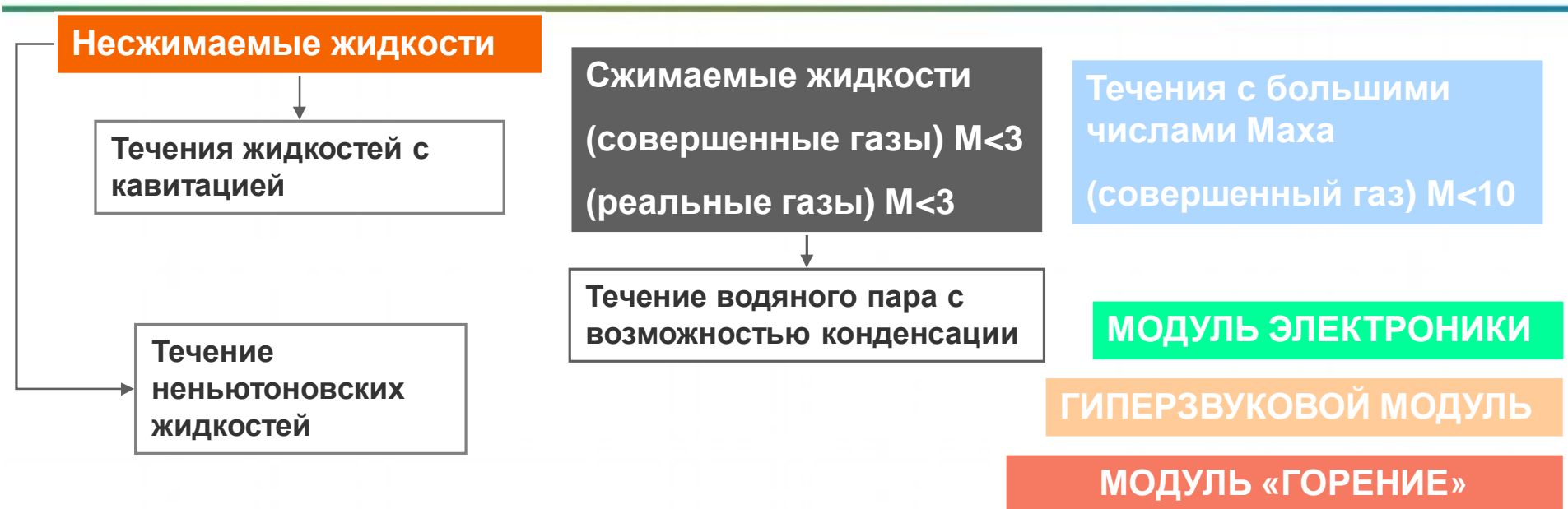

ОСНОВНЫЕ РАСЧЕТНЫЕ ОПЦИИ:

- стационарный или нестационарный расчет
- теплопроводность в жидкостях и твердых телах (изотропная и анизотропная)
- радиационный теплообмен (полупрозрачные тела)
- конвекция и естественная конвекция
- вращение (турбины, насосы, вентиляторы)

ИСПОЛЬЗУЕМЫЕ УПРОЩЕННЫЕ МОДЕЛИ:

- вентиляторы и теплообменник с вентилятором
- контактное сопротивление (тепловое и электрическое)
- термо-электрический элемент (ТЕС)
- пористые среды

Кавитация в топливной форсунке *

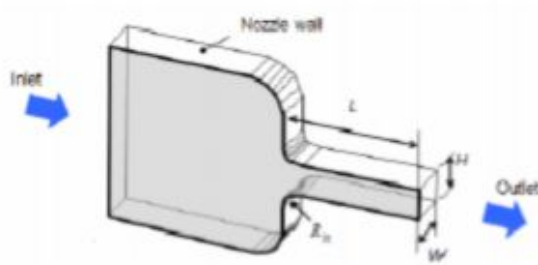
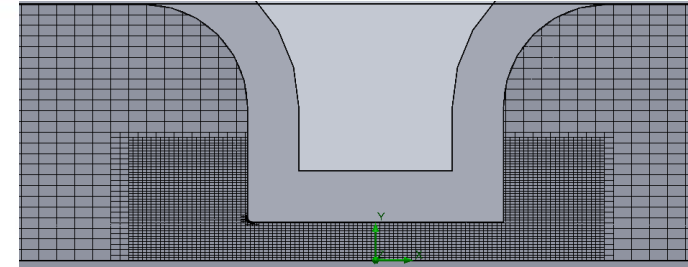
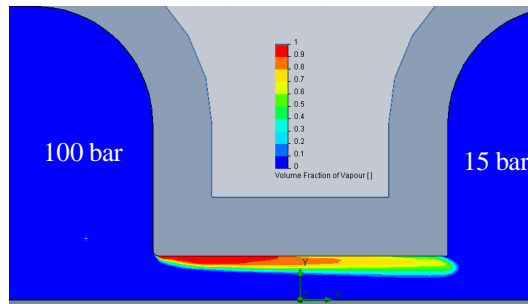
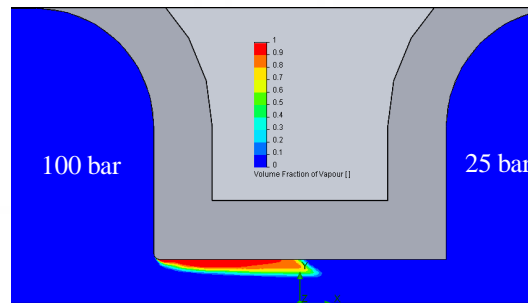
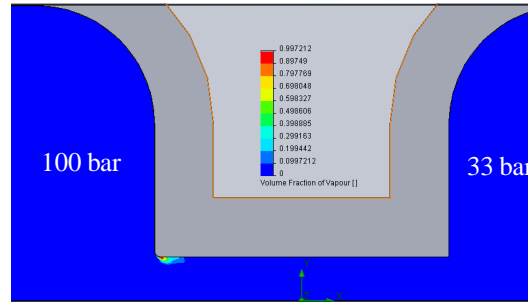
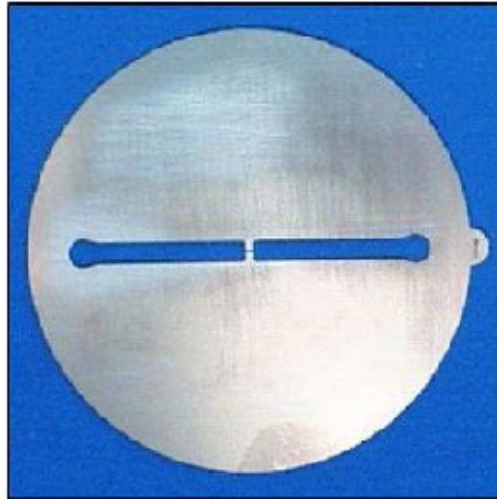

$L=0.001$ m, $H=0.000299$ m,
 $W=0.0003$ m, $R_{in}=0.00002$ m

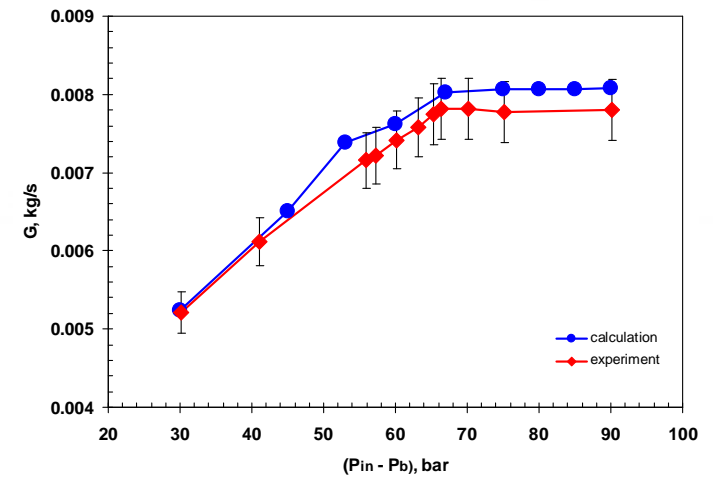

Mass flow rate through the injector
versus pressure drop

* Winklhofer, E., Kull, E., Kelz, E., and Morozov, A., 2001, "Comprehensive Hydraulic and Flow Field Documentation in Model Throttle Experiments Under Cavitation Conditions." ILASS Europe 2001.

Насос с кавитацией *

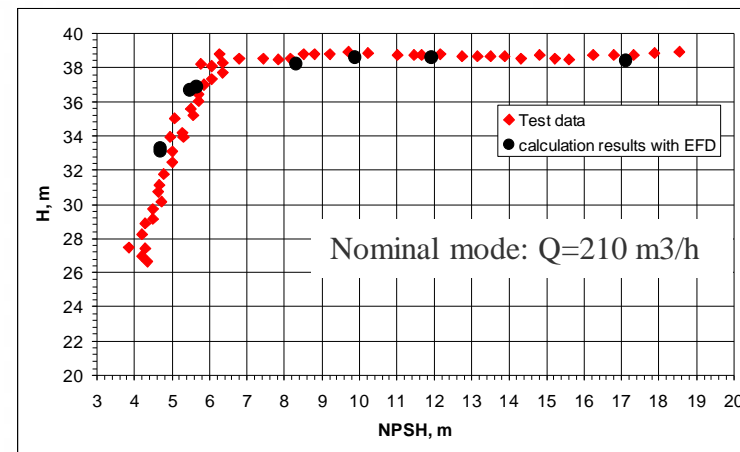
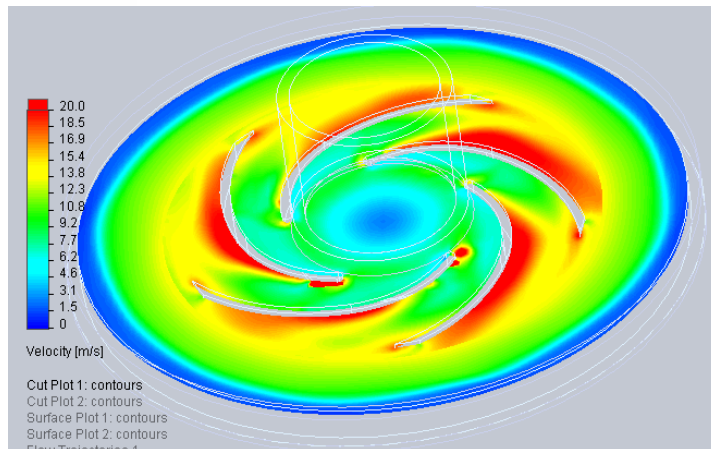
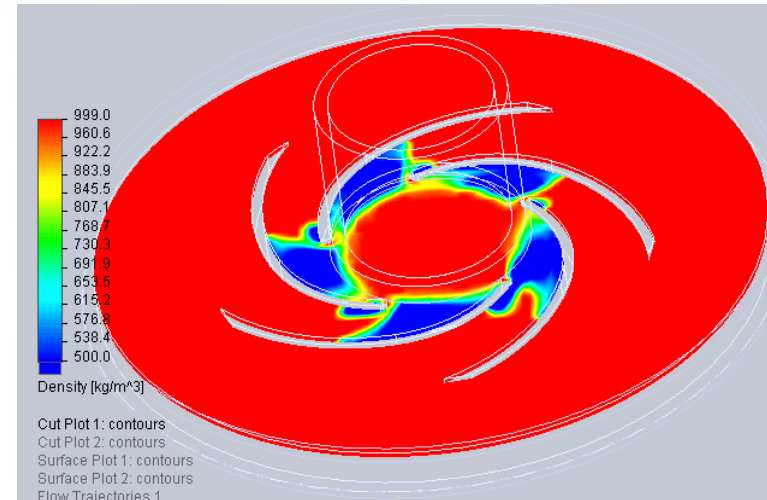
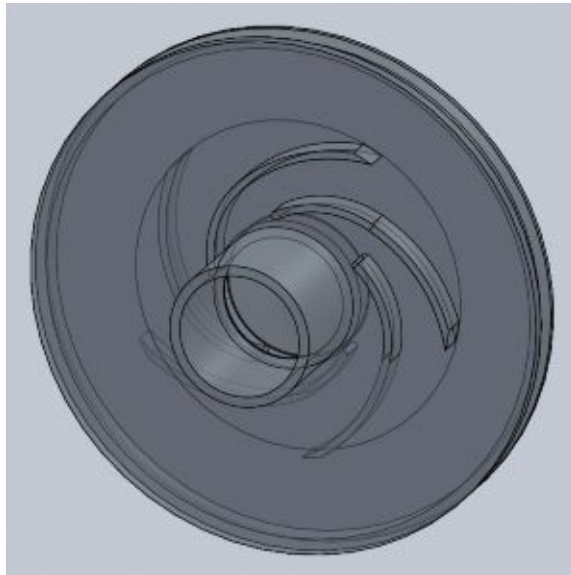

*M.Hofman, B.Stoffel, O.Coutier-Delgosha, R.Fortes-Platella, JI.Reboud, Experimental and numerical studies on a centrifugal pump with 2D-curved blades in cavitation condition, CAV2001:session B7.005

Горение предварительно перемешанной метано-воздушной смеси*

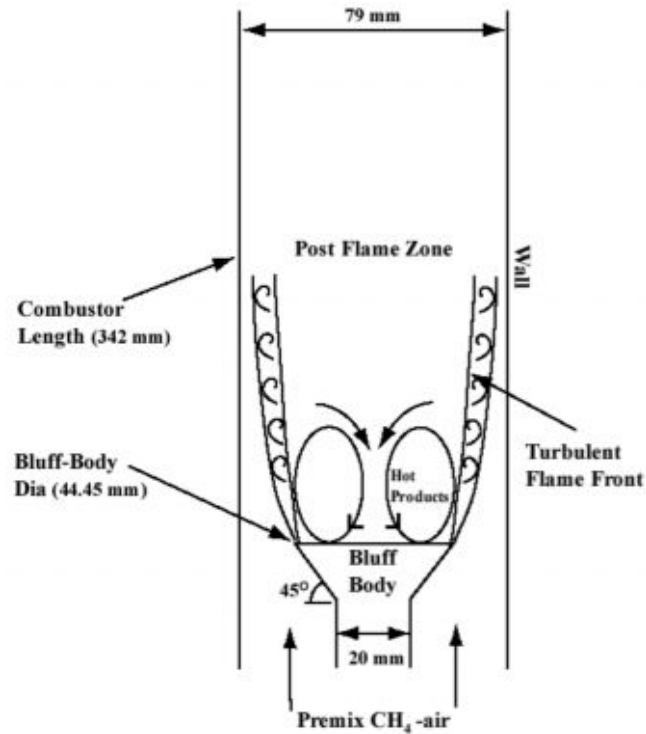

Component	Mass Fraction, %
Fuel (Methane)	3.29
Oxidizer (Air)	96.71

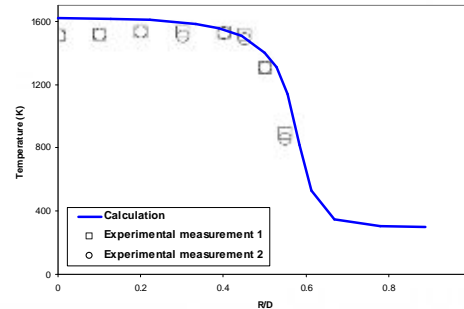
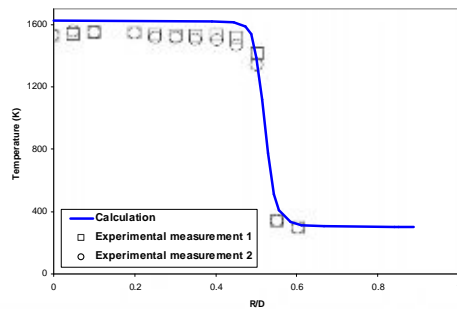
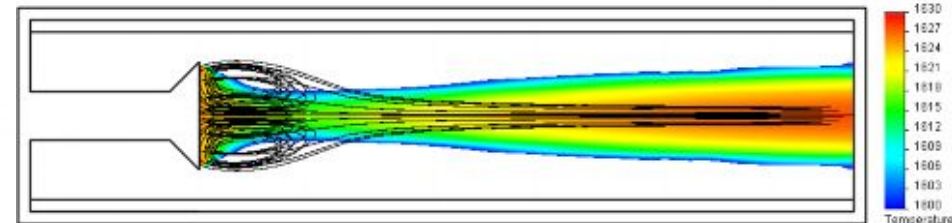

* Nandula, S.P., Pitz, R.W., Barlow, R.S., and Fiechtner, G.J., (1996), "Rayleigh/Raman/LIF Measurements in a Turbulent Lean Premixed Combustor", AIAA 96-0937, 34th Aerospace Sciences Meeting & Exhibit, Reno, NV, January 15-18, 1996

Теплообменник для электроники

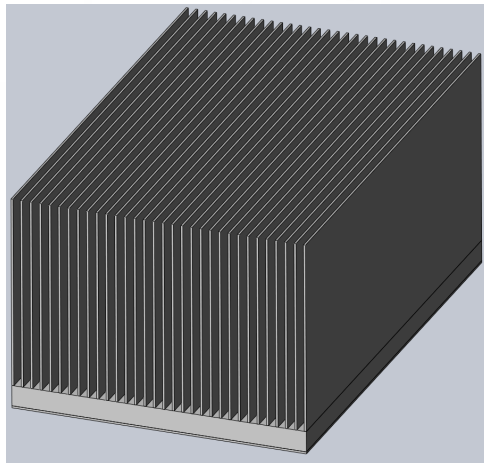
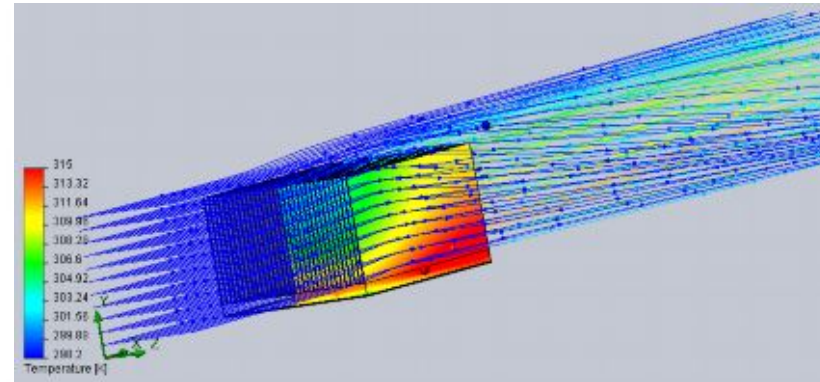
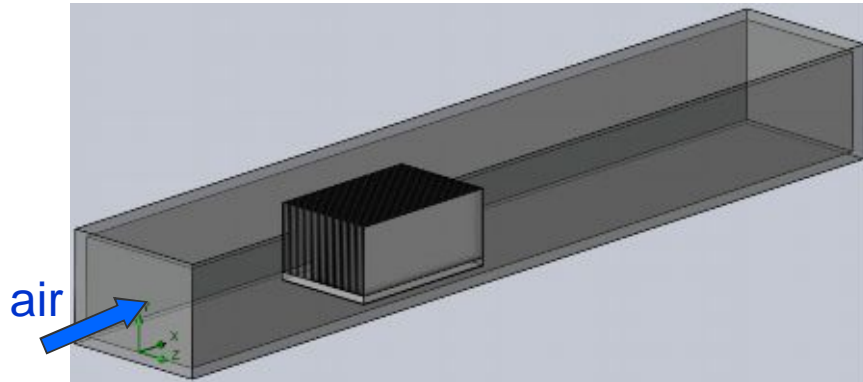

	EFD 9.1.1				EFD 9.2			
$V, \text{ m/s}$	3		5		3		5	
$R_{t \text{ exp}}, \text{ K/W}^*$	0.1844		0.1429		0.1844		0.1429	
Mesh resolution Mesh cells	RRL1 64 119	RRL3 396 968	RRL1 64 119	RRL3 396 968	RRL1 64 119	RRL3 396 968	RRL1 64 119	RRL3 396 968
$R_{t \text{ calcul}}, \text{ K/W}$	0.2153	0.2000	0.1793	0.1564	0.1936	0.1960	0.1452	0.1480
$\delta, \%$	16.8	8.5	25.7	9.5	5	6.3	1.6	3.6

Mesh RRL3 corresponds to automatic mesh settings RRL3 and local mesh around heat sink with its detail resolution

*Susana Prstic, Madhusudan Iyengar, Avram Bar-Cohen, "Bypass effect in high performance heat sink", International Thermal Sciences Conference in Bled, Slovenia, June 11-14, 2000.

Ребристо-пластинчатый теплообменник

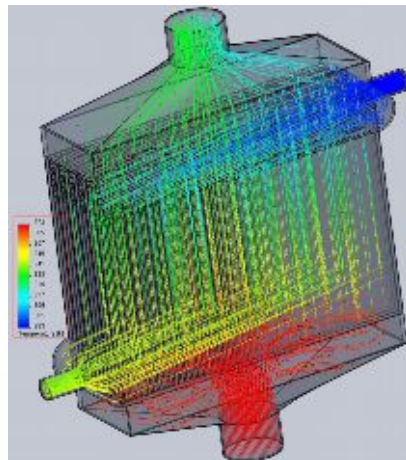
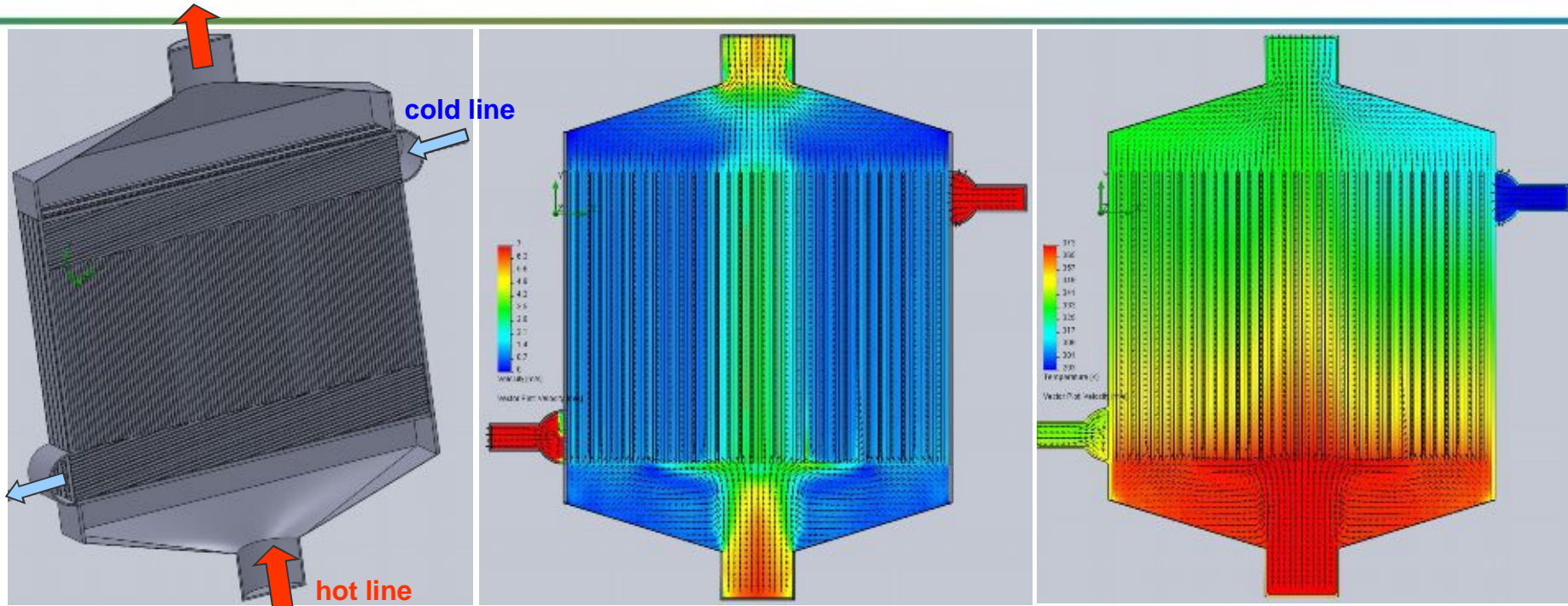

Hot line: $m=39.1$ kg/h, $t=100$ C, working body - air
 Cold line: $m=36$ kg/h, $t=20$ C, working body – air
 Heat exchanger material - aluminum

Mesh: automatic RRL4
 Number of cells – 161 514

Calculation//engineering estimation					
Hot line			Cold line		
ΔP , Pa	Q, W	Δt	ΔP , Pa	Q, W	Δt
56//66	475//500	43.3//45.6	6631//6785	475//500	45.3//49.6

Алюминиевый поперечно-проточный пластинчато-ребристый теплообменник

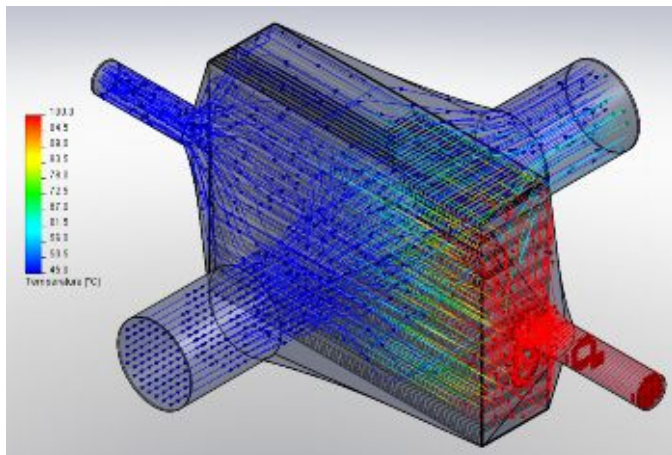
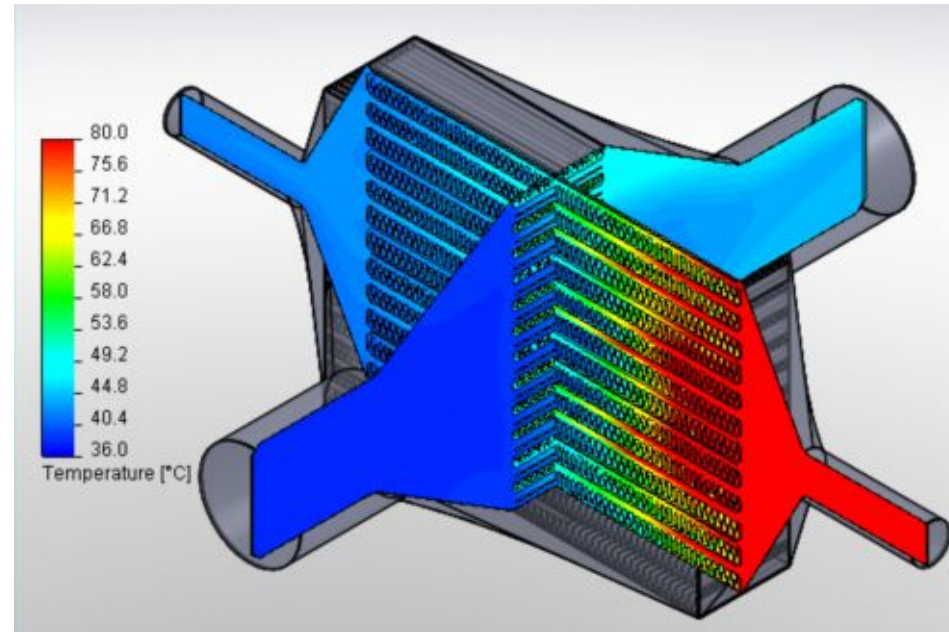
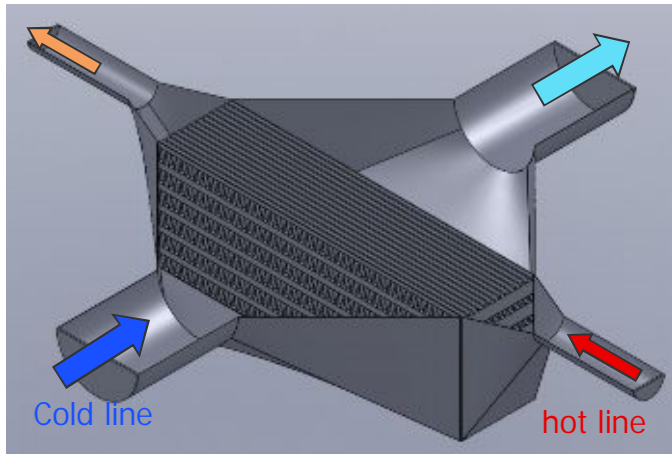

Working body – air

$\alpha=5.5 \text{ W}/(\text{m}^2\text{K})$; $t_{\infty}=20 \text{ C}$

	Level 3*	Level 5**	Test data
$t_{\text{in}}^{\text{cold}}, \text{C}^{\circ}$	38.06	38.06	38.06
$t_{\text{out}}^{\text{cold}}, \text{C}^{\circ}$	48.29	48.33	45.4
$t_{\text{in}}^{\text{hot}}, \text{C}^{\circ}$	159.7	159.7	159.7
$t_{\text{out}}^{\text{hot}}, \text{C}^{\circ}$	41.55	43.89	42.23

* - N=159 836; ** - N=1 000 272

Расчет вихревой форсунки (природный газ.воздух)*

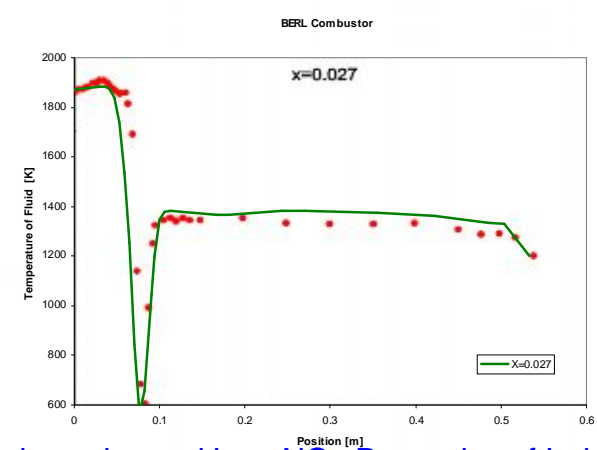
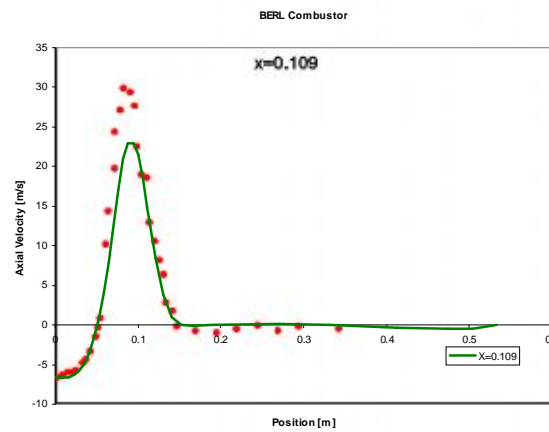
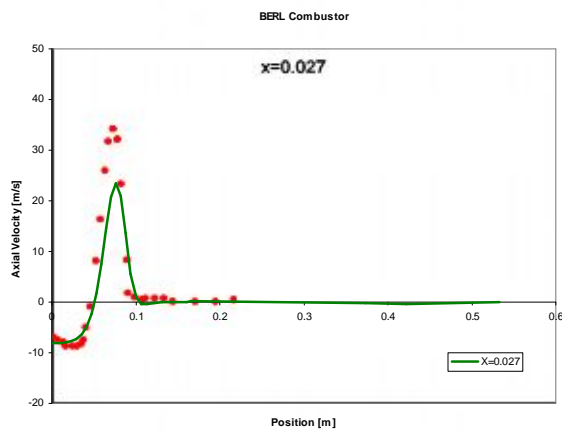
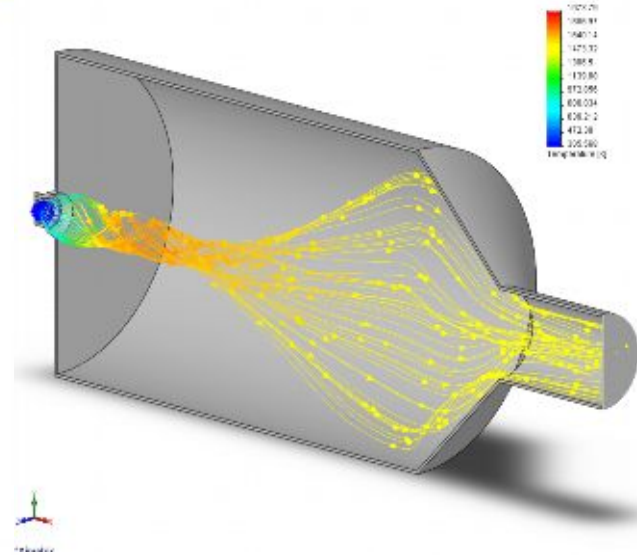
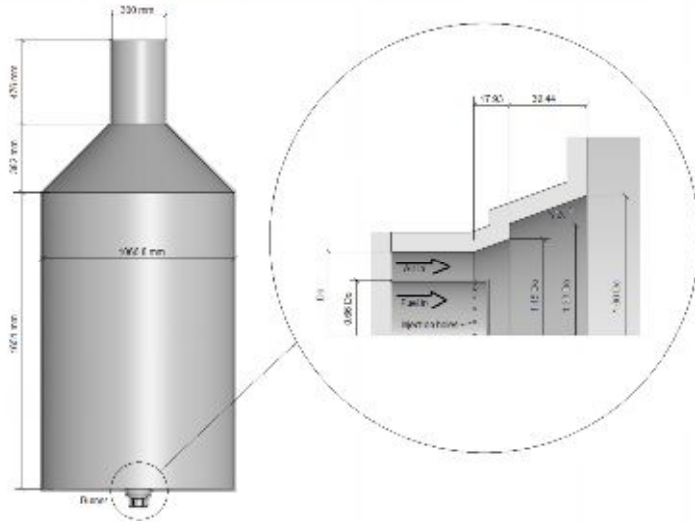

* Sayre A, N. Lallemand, J. Dugue, R. Weber, 1994, Scaling Characteristics of Aerodynamics and Low-NO_x Properties of Industrial Natural Gas Burners, The SCALING 400 Study, Part IV: The 300 kW BERL Test Results, IFRF Doc No F40/y/11, International Flame Research Foundation, The Netherlands.

Испытания ERCOFTAC *

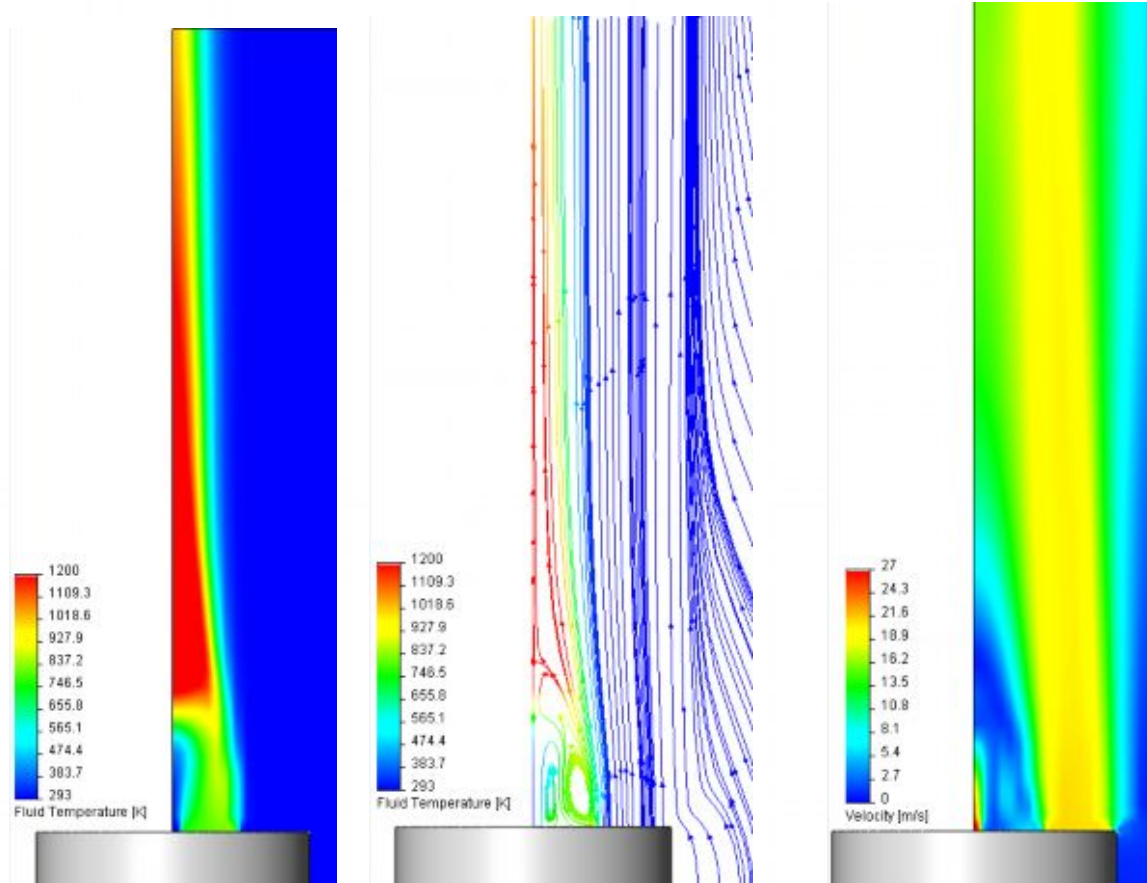
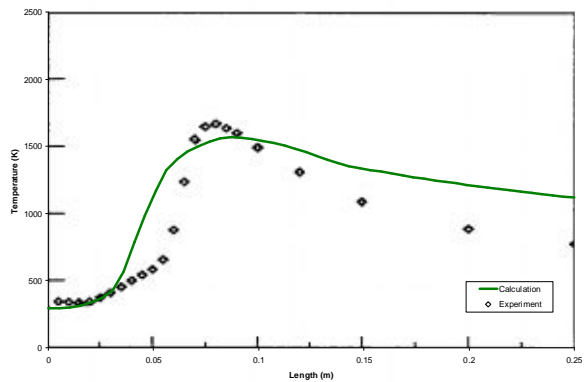
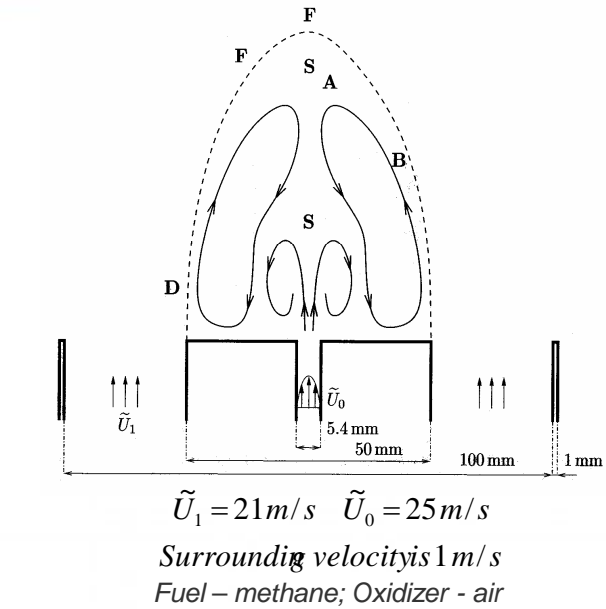

* Fallot, L., Gonzalez, M., Elamraoui, R. and Obounou, M. Modelling finite-rate chemistry effects in non-premixed turbulent combustion: test on the bluff-body stabilized flame”, Comb. Flame, 1997, 110, pp. 298-318.

Горение за стабилизатором пламени *



Premixed mixture at 140 C
Fuel – gasoline
Oxidizer - air

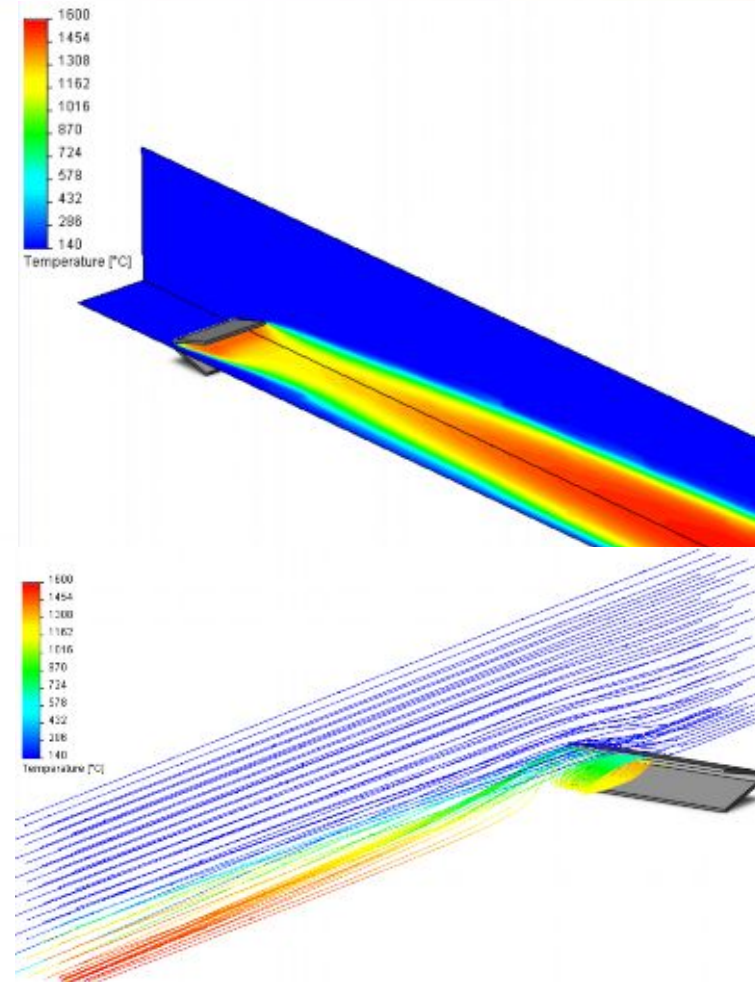
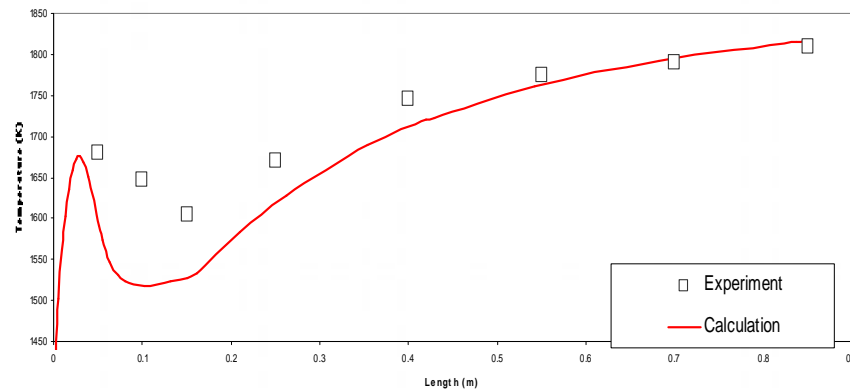

* V.P. Solntsev, V.A. Golubev, Investigation of the combustion process of gasoline-air mixture in turbulent trail of the flameholders “Aviatsionnaya tekhnika”, 1959, Kazan’

Расчет тепло элемента нагревателя Hoval

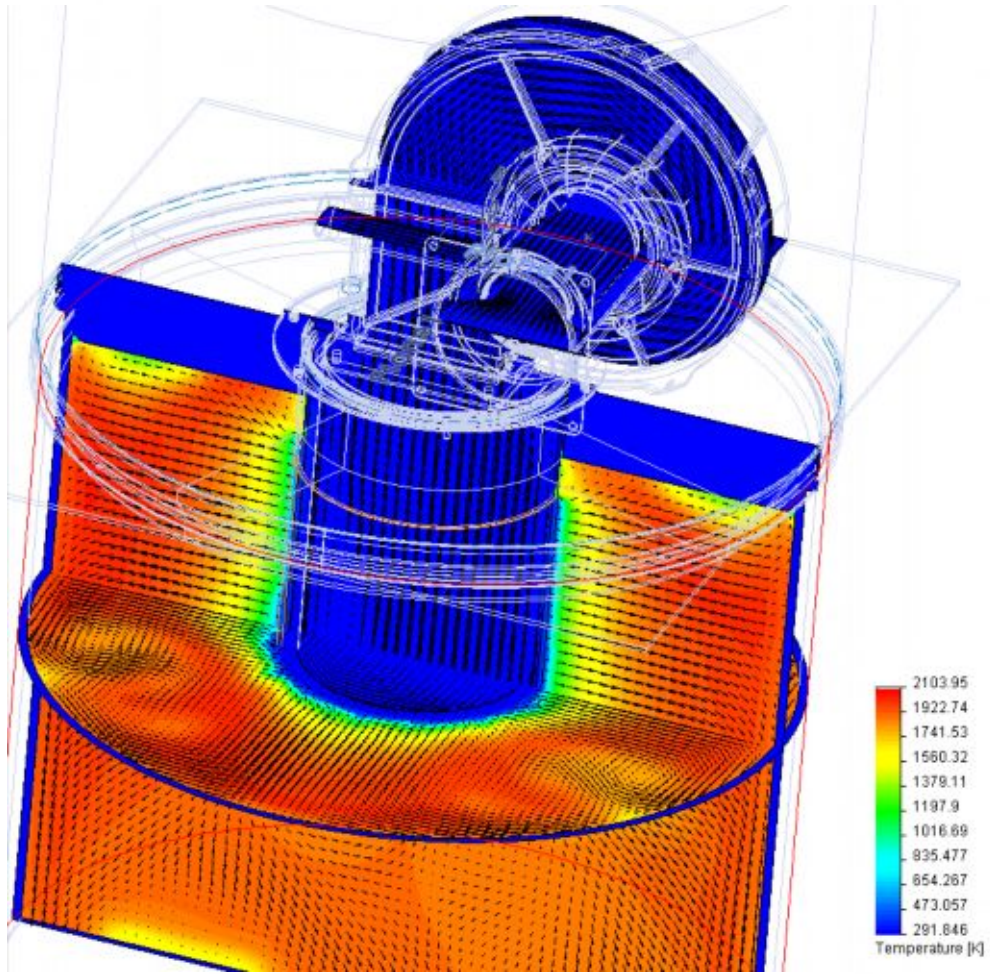
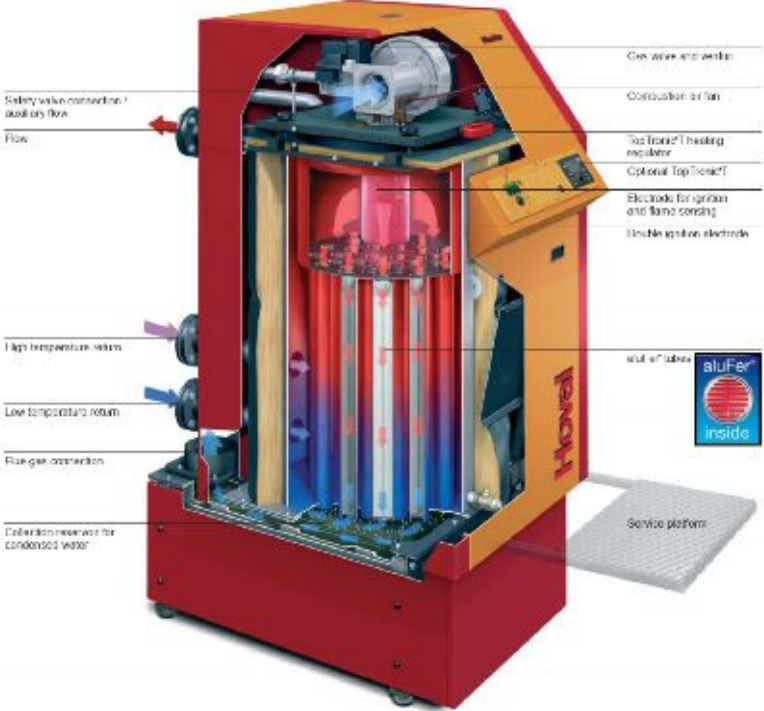
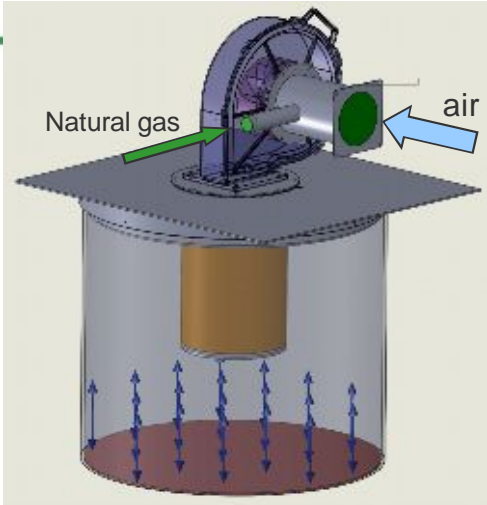

Расчет горения факелов попутных газов*

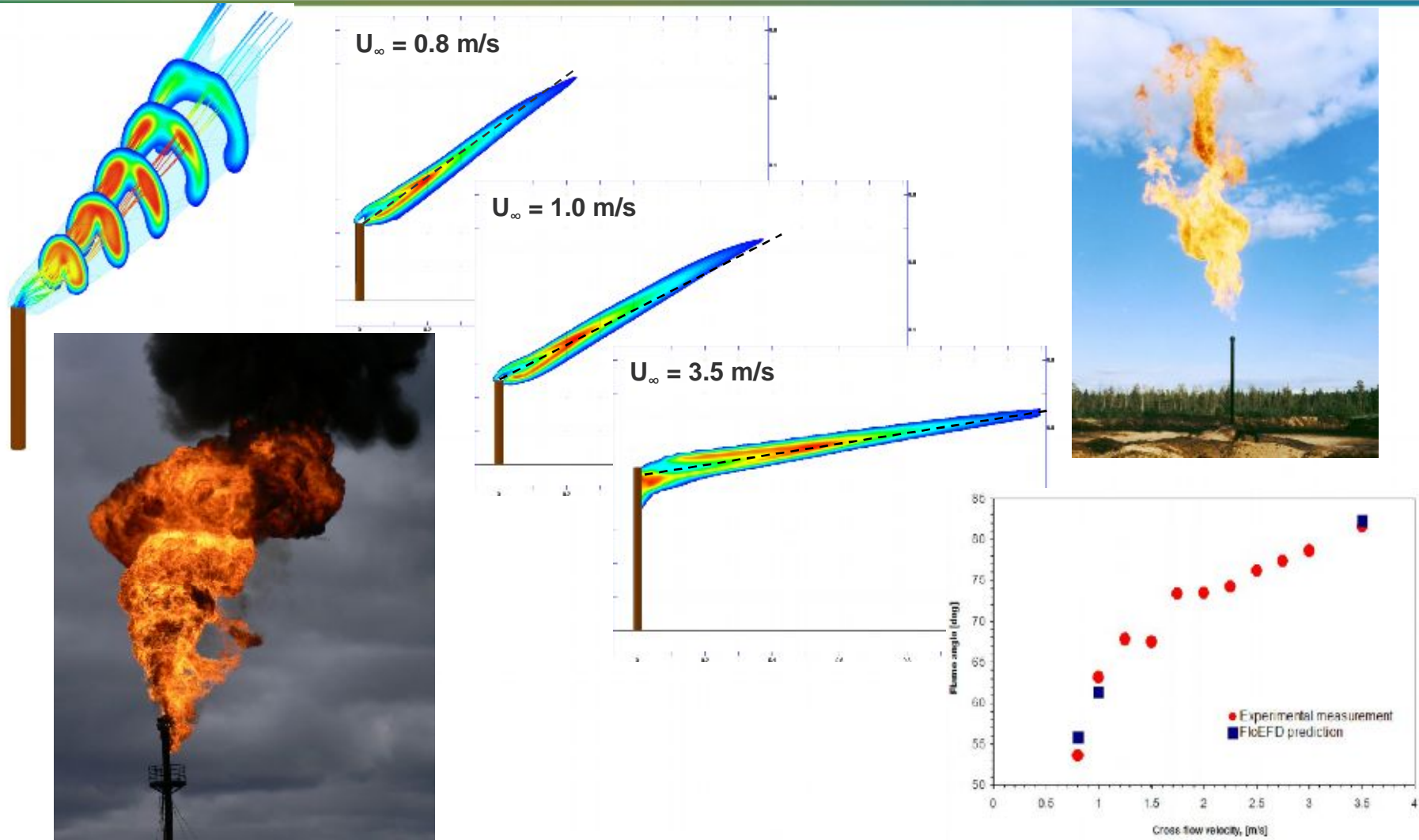

* Larry Kostiuk, Matthew Johnson, Glen Thomas, University of Alberta, Flare Research Project, Final Report, September 2004

РАСЧЕТ НАСОСОВ, КОМПРЕССОРОВ, ВЕНТИЛЯТОРОВ

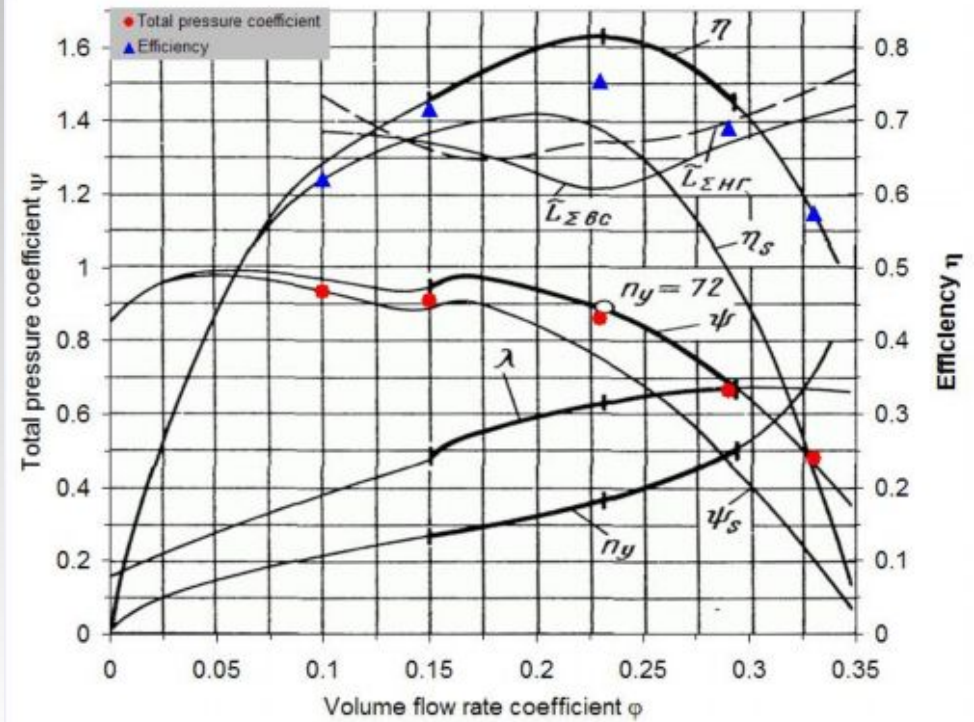
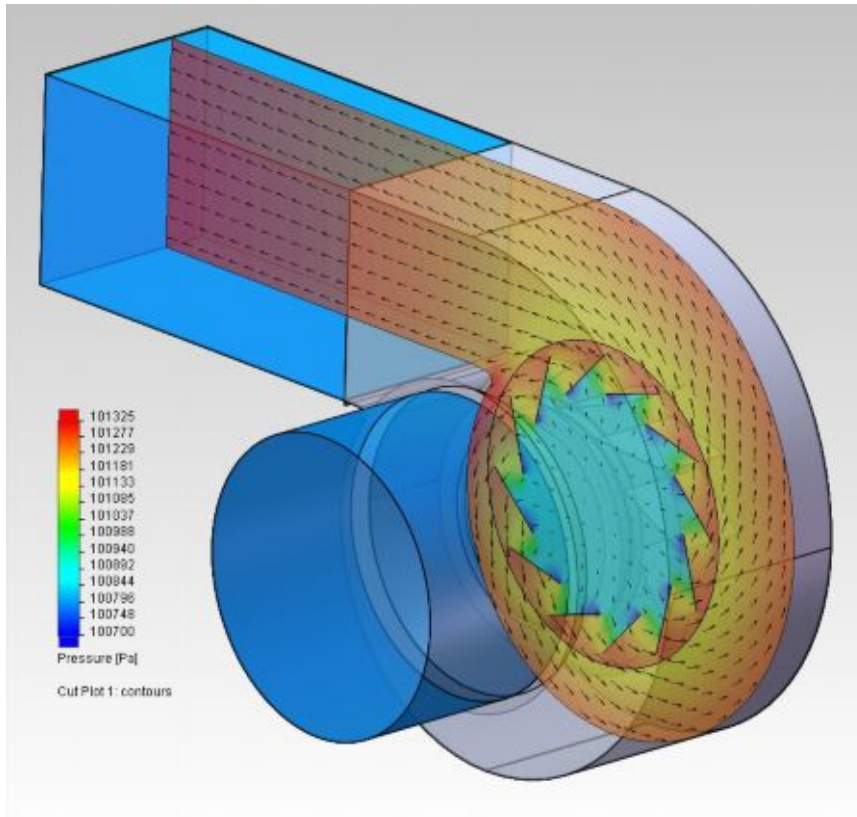

Течения в циклонах

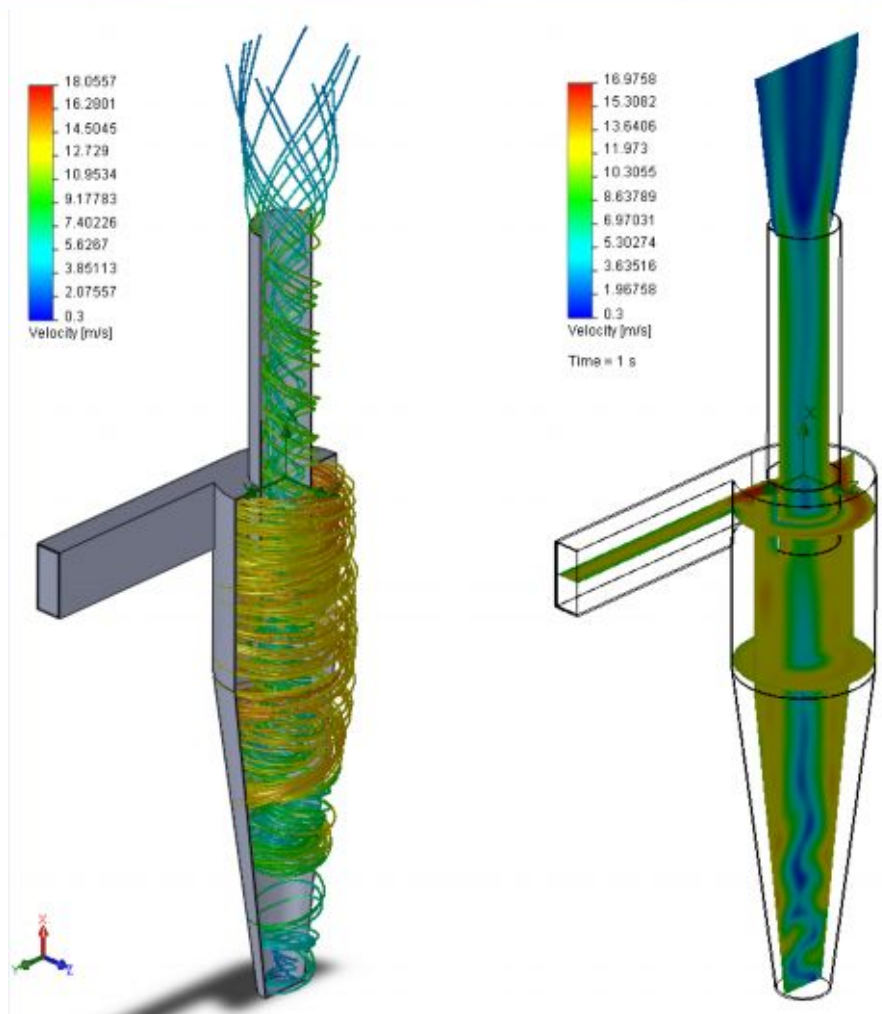

Comparison of predicted and measured total pressure drop for a Stairmand HE cyclone

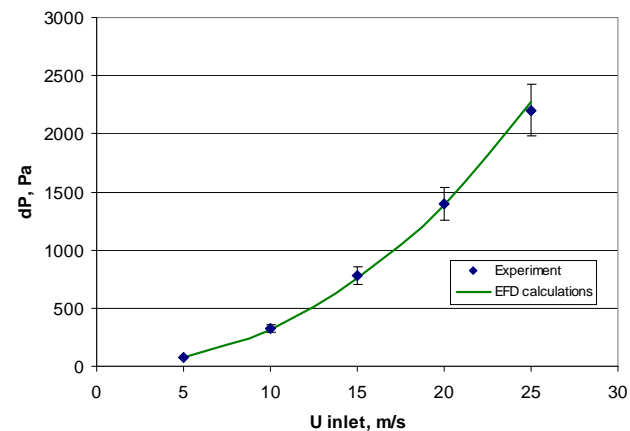

Time evolution of the total pressure drop of a Stairmand HE cyclone at 10 m/s gas inlet velocity

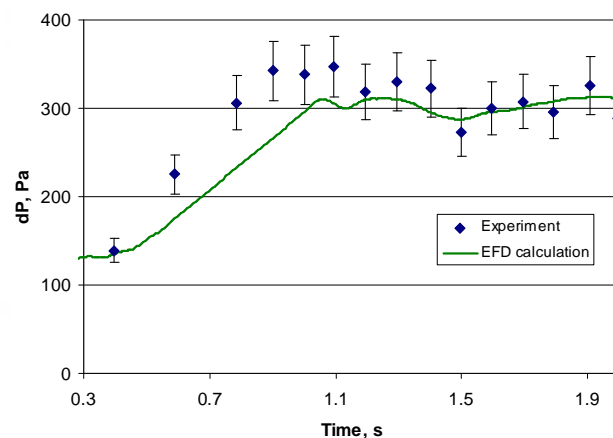

Reference: Griffiths, W.D., Boysan, F., 1996, "Computational fluid dynamics (CFD) and empirical modelling of the performance of a number of cyclone samplers", J. Aerosol Sci, Vol 27, №2, 281-304

Расчет вентиляции и кондиционирования

Кондиционирование комнаты с двумя боксами

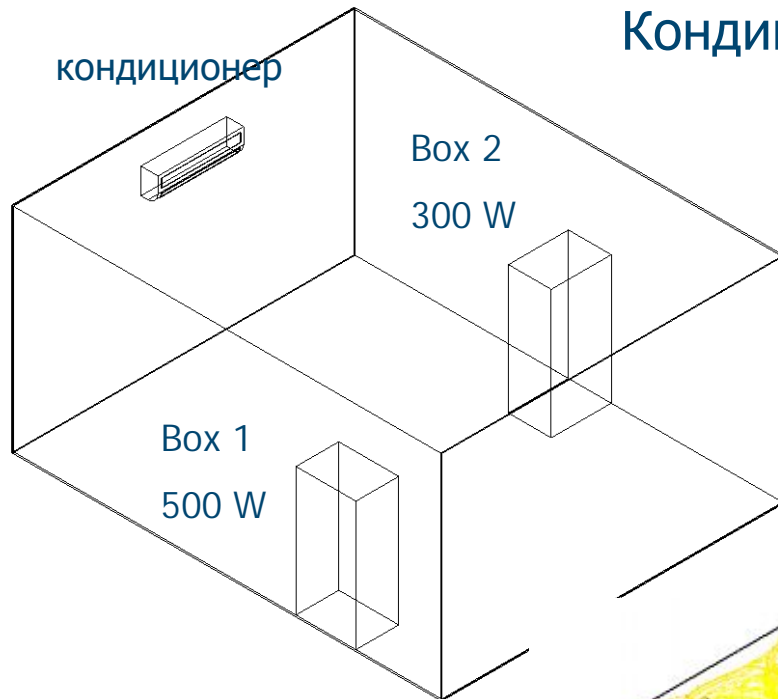

Кондиционируемая комната - теплоизолирована.
Box 1 выделяет 500 W and box 2 выделяет 300 W

Кондиционер работает при фиксированном
расходе (0.07 m³/s) и выходной
температуре - 20 C.

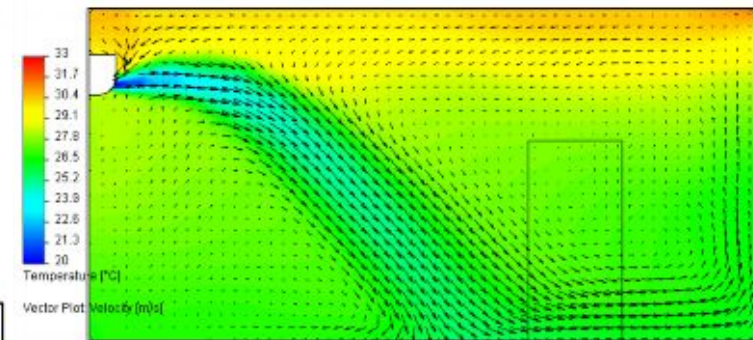
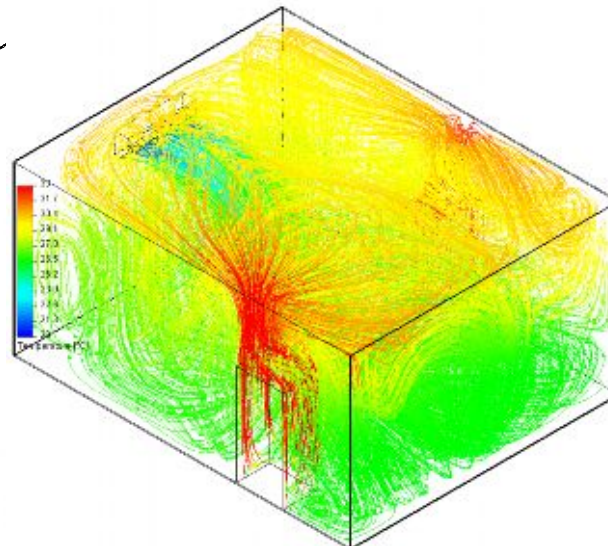

**Mentor
Graphics®**

www.mentor.com